

ITEM NO.	PART NUMBER	DESCRIPTION	QTY.
1	TIG A	6 X 4.5 X .075	1
2	TIG B	5 X 3 X .075	1
3	TIG C	5 X 3 X .075	1
4	TIG D	4.2 X 4.15 X .075	2
5	TIG E	6 X 3 X .075	2

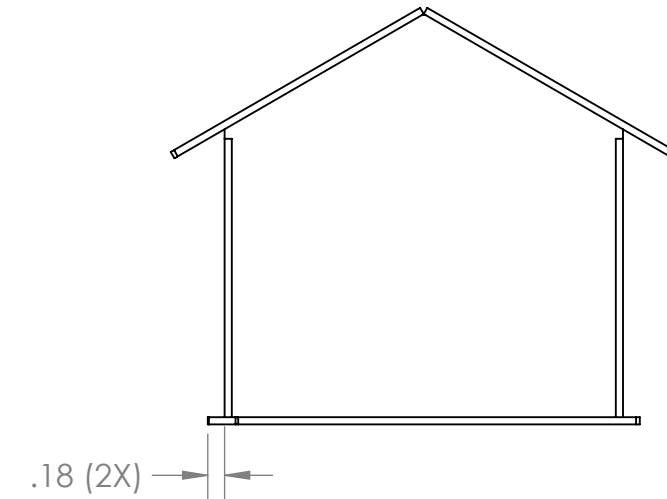
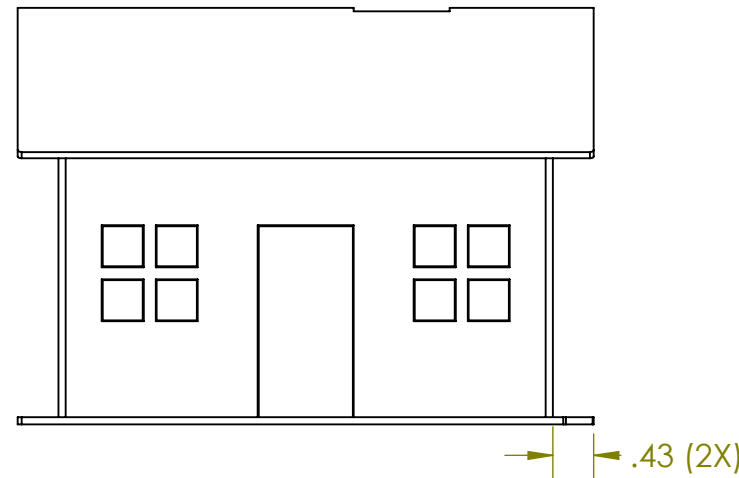
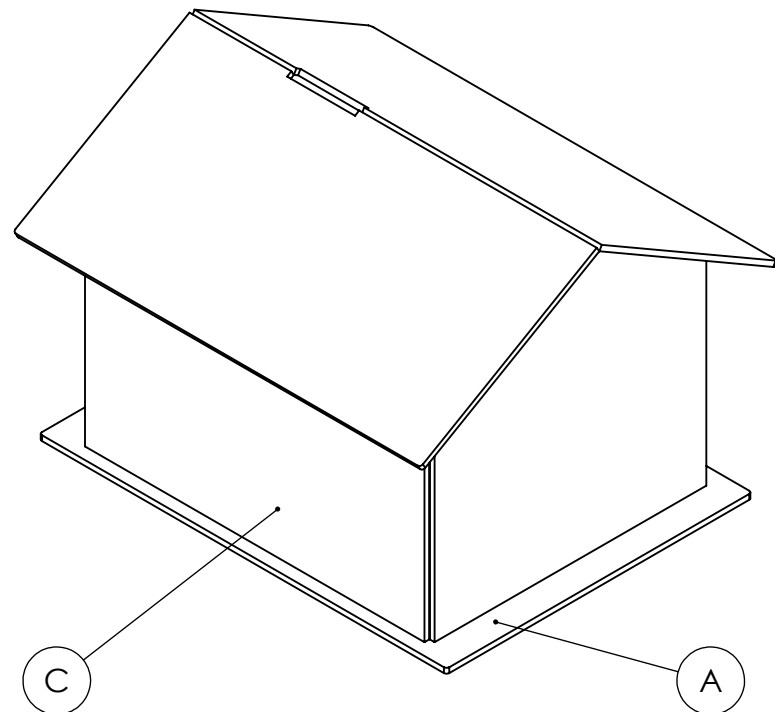
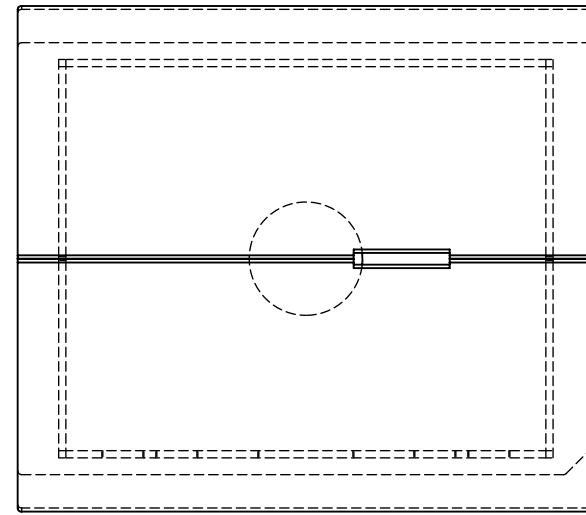
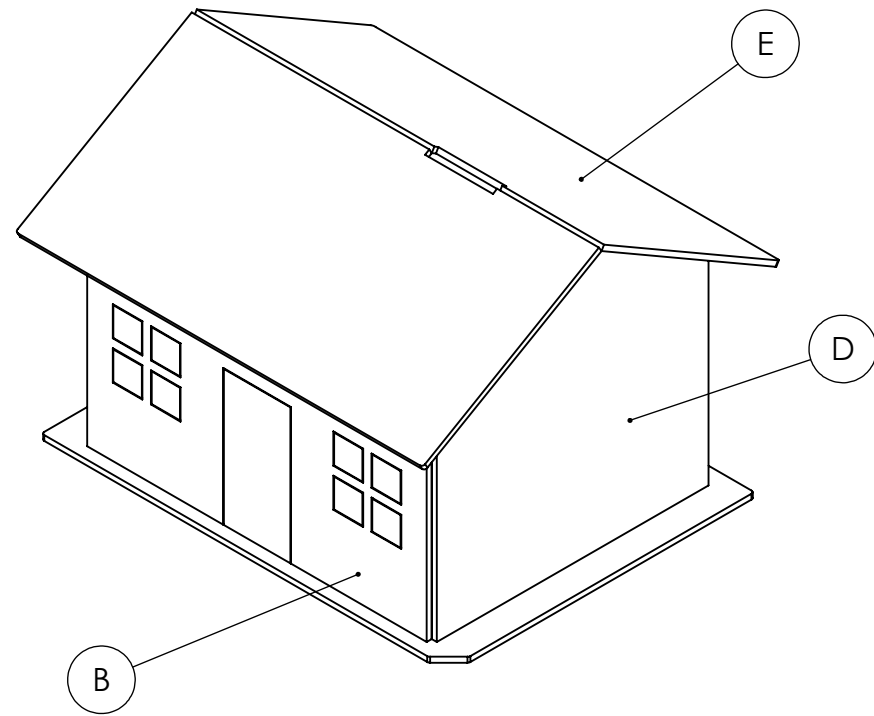

REVISION	DESCRIPTION	DATE	BY

UNLESS OTHERWISE SPECIFIED:
 DIMENSIONS ARE IN INCHES.
 TOLERANCES:
 ANGULAR: ±1/2°
 ONE PLACE DECIMAL ±.1
 TWO PLACE DECIMAL ±.06
 THREE PLACE DECIMAL ±.030

SCALE 1:2
 DO NOT SCALE DRAWING
 SHEET: 1 OF 1

MATERIAL:	REV.
TITLE:	-
DWG. NO. TIG TEST	